

eurolite® LED TRIPLE FX LASER BOX

3in1 Lighting Effect

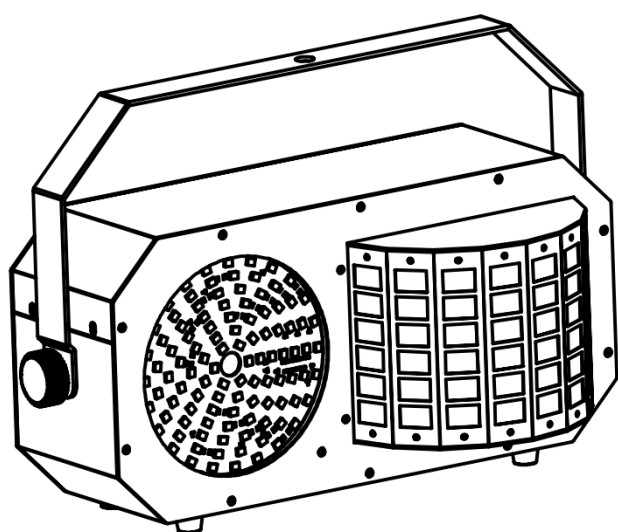

Bedienungsanleitung
User Manual

eurolite®

LED Laser Slim FX Spot

3in1-Lichteffekt mit LED-Derby, RG-Laser und Stroboskop
3in1 lighting effect with LED derby, RG laser and stroboscope



No. 51741077

www.eurolite.de

USER MANUAL

eurolite®

LED Triple FX Laser Box



DANGER! Electric shock caused by short-circuit

Be careful with your operations. With a dangerous voltage you can suffer a dangerous electric shock when touching the wires. Never open the housing. Keep the device away from rain and moisture.



Please read these instructions carefully before using the product. They contain important information for the correct use of the product.

Every person involved with the installation, operation and maintenance of this device has to

- be qualified
- follow the instructions of this manual
- consider this manual to be part of the total product
- keep this manual for the entire service life of the product
- pass this manual on to every further owner or user of the product
- download the latest version of the user manual from the Internet

INTRODUCTION

Thank you for having chosen one of our products. If you follow the instructions given in this manual, we are sure that you will enjoy this device for a long period of time.

Product features

3in1 light effect with LED derby, RG laser and stroboscope

- Rotating derby effect with 2 high-power 10 W RGBW LEDs (4in1)
- 105 RGB LEDs (0.2 W each) for fast, dynamic strobe and wash effects
- 2 laser diodes project different shapes in different colors
- Laser class 2M: does not require additional protective measures or appointment of a laser safety officer
- LED derby, laser and strobe can be controlled individually
- Auto, music, master/slave and DMX mode
- 7 built-in auto and music show programs
- Direct color selection for 15 preset colors
- Addressing and setting via control panel with 4-digit LED display
- Convenient wireless control via included IR remote control EUROLITE IR-26
- Sound-control via built-in microphone with adjustable microphone sensitivity
- DMX512 control possible via any commercial DMX controller
- 2 or 14 DMX channels selectable for various applications
- Swivel mounting bracket
- Feed-through output allows to power up to 8 devices

SAFETY INSTRUCTIONS

**WARNING!**

Please read the safety warnings carefully and only use the product as describe in this manual to avoid accidental injury or damage.

Intended use

- This device is a laser projector for creating decorative lighting effects. This device is designed for professional use in the field of event technology, e.g. on stage. It is not suitable for household lighting.
- Only use the device according to the instructions given herein. Damages due to failure to follow these operating instructions will void the warranty! We do not assume any liability for any resulting damage.
- We do not assume any liability for material and personal damage caused by improper use or non-compliance with the safety instructions. In such cases, the warranty/guarantee will be null and void.
- Unauthorized rebuilds or modifications of the device are not permitted for reasons of safety and render the warranty invalid.

Danger due to electricity

- The device is suitable for indoor use only. Do not use it outdoors. Never expose it to rain or moisture. Do not store it in rooms exposed to moisture.
- To reduce the risk of electric shock, do not open any part of the device. There are no serviceable parts inside the device.
- Only connect the device to a properly installed mains outlet. The outlet must be protected by residual current breaker (RCD). The voltage and frequency must exactly be the same as stated on the device. If the mains cable is equipped with an earthing contact, then it must be connected to an outlet with a protective ground. Never defeat the protective ground of a mains cable. Failure to do so could result in damage to the device and possibly injure the user.
- The mains outlet must be easily accessible so that you can unplug the device quickly if need be.
- Never touch the mains plug with wet or damp hands. There is the risk of potentially fatal electric shock.
- The mains cable must not be bent or squeezed. Keep it away from hot surfaces or sharp edges.
- Never pull the mains cable to disconnect the mains plug from the mains outlet, always seize the plug.
- Unplug the device during lighting storms, when unused for long periods of time or before cleaning.
- Do not expose the device to any high temperatures, direct sunlight, dripping or splashing water, strong vibrations or heavy mechanical stress.
- Do not place any objects filled with liquids on the device.
- Do not place any open sources of fire, such as burning candles, on or directly next to the device.
- Make sure that objects cannot fall into the device, in particular metal parts.
- Only have repairs to the device or its mains cable carried out by qualified service personnel. Repairs are required when the device or the mains cable is visibly damaged, liquid has been spilled or objects have fallen into the device; when the device has been exposed to rain or moisture, has been dropped or malfunctions occur.
- Cleaning of the device is limited to the surface. Make sure that moisture does not come into contact with any areas of the terminal connections or mains voltage control parts. Only wipe off the product with a soft lint-free and moistened cloth. Never use solvents or aggressive detergents.

Danger to children and people with restricted abilities

- This product is not a toy. Keep it out of the reach of children and pets. Do not leave packaging material lying around carelessly. Never leave this device running unattended.
- This device may be used only by persons with sufficient physical, sensorial, and intellectual abilities and having corresponding knowledge and experience. Other persons may use this device only if they are supervised or instructed by a person who is responsible for their safety.

Warning – risk of burns and fire

- The admissible ambient temperature range (Ta) is -5 to +45°C. Do not operate the device outside of this temperature range.
- The housing temperature (Tc) can be up to 50°C during use. Avoid contact by persons and materials.
- Do not illuminate surfaces within 1 m of the device. This value is indicated on the device by the  symbol.
- Do not use the device near highly flammable materials. Always place the device at a location where sufficient air circulation is ensured. Leave 50 cm of free space around the device. Never cover the air vents of the housing.
- Only operate the device in moderate climate, never in tropical climate.

Warning – risk of injuries

- Do not look directly at the light source. Persons with light-sensitive epilepsy may suffer from epileptic seizures or fall unconscious.
- Make sure that the product is set up or installed safely and expertly and prevented from falling down. Comply with the standards and rules that apply in your country, in particular EN 60593-2-17.
- If you lack the qualification, do not attempt the installation yourself, but instead use a professional installer. Improper installation can result in bodily injury and or damage to property.
- The manufacturer cannot be made liable for damages caused by incorrect installations or insufficient safety precautions.
- For overhead use, always secure the device with a secondary safety attachment such as a safety bond or safety net.
- Make sure that the area below the installation place is blocked when rigging, derigging or servicing the device.
- For commercial use the country-specific accident prevention regulations of the government safety organization for electrical facilities must be complied with at all times.

Caution – material damage

- This device must not be connected to the mains voltage by means of a dimmer.
- Lighting effects are not designed for permanent operation. Consistent operation breaks will ensure that the device will serve you for a long time without defects.
- Never switch the device on and off at short intervals. This will considerably reduce the service life of the device.
- If the device has been exposed to drastic temperature fluctuation, do not switch it on immediately. The resulting condensation may destroy the device. Allow the device to reach room temperature before connecting it. Wait until the condensation has evaporated.
- Please use the original packaging to protect the device against vibration, dust and moisture during transportation or storage.
- If a serial number label is affixed to the device, do not remove the label as this would make the guarantee void.

About batteries

- Do not try to short-circuit, recharge, disassemble or heat batteries (danger of explosion!).
- Remove the batteries if the device is not used for a longer period of time.
- Damaged/leaking batteries may cause harm to your skin–use safety gloves.



Important information for laser products

	<p>DANGER! Avoid direct eye exposure. Never view directly with optical instruments (e.g. magnifying lens or telescope). Laser radiation can cause eye damage and/or skin damage. All protective measures for a safe operation of this laser must be applied.</p>	<div style="border: 2px solid black; padding: 5px; width: fit-content; margin: 0 auto;"> <p style="margin: 0;">LASER RADIATION Do not stare into the beam or view directly with optical instruments 2M LASER PRODUCT EN 60825-1:2014 P_e < 1mW λ = 532/650nm</p> </div>
---	--	--

Safety measures which must be observed

- This device includes a class 2M laser according to the EN 60825-1. The accessible laser radiation is exclusively within the visible spectral range (400 nm to 700 nm). However, a short-term exposure (max. 0.25 seconds) is not hazardous to the eye. A longer exposure is prevented by the natural eyelid closing reflex. Nevertheless, close your eyes or turn away immediately if the laser beam hits the eye. The corresponding warning is attached to the housing.
- The operator must comply with the country-specific accident prevention regulations of the government safety organization for electrical facilities.
- The corresponding accident prevention regulation of the accident prevention and insurance association in Germany is BGV-B2.
- This product must only be mounted, commissioned and operated by suitably qualified specialist personnel and only under observance of the requirements stated in the operating instructions.
- The use of operating and adjustment equipment and procedures other than those indicated here can lead to dangerous exposure to radiation.
- Do not stare into the laser beam and do not aim the laser at another person or animals. Laser radiation may result in injuries to the eyes or skin.
- Do not look into the laser beam with optical instruments (e.g. magnifying glasses or binoculars) under any circumstances. Laser radiation can cause eye damage and/or skin damage.
- Do not point the laser beam at mirrors or other reflective surfaces. The uncontrolled, reflected beam may strike people or animals.
- Always set up and install the unit so that a minimum distance of 1 m is kept between the laser light and the audience.
- Mark the area where this laser equipment is used by means of barriers and warning signs etc.
- Caution laser diode! Do not open or modify the unit. A modification can result in a more hazardous laser radiation which considerably deviates from the specified values.

PROTECTING THE ENVIRONMENT

	<p>Disposal of old equipment When to be definitively put out of operation, take the product to a local recycling plant for a disposal which is not harmful to the environment. Devices marked with this symbol must not be disposed of as household waste. Contact your retailer or local authorities for more information. Remove any inserted batteries and dispose of them separately from the product.</p>
	<p>You as the end user are required by law (Battery Ordinance) to return all used batteries/rechargeable batteries. Disposing of them in the household waste is prohibited. You may return your used batteries free of charge to collection points in your municipality and anywhere where batteries/rechargeable batteries are sold. By disposing of used devices and batteries correctly, you contribute to the protection of the environment.</p>

DESCRIPTION OF THE DEVICE

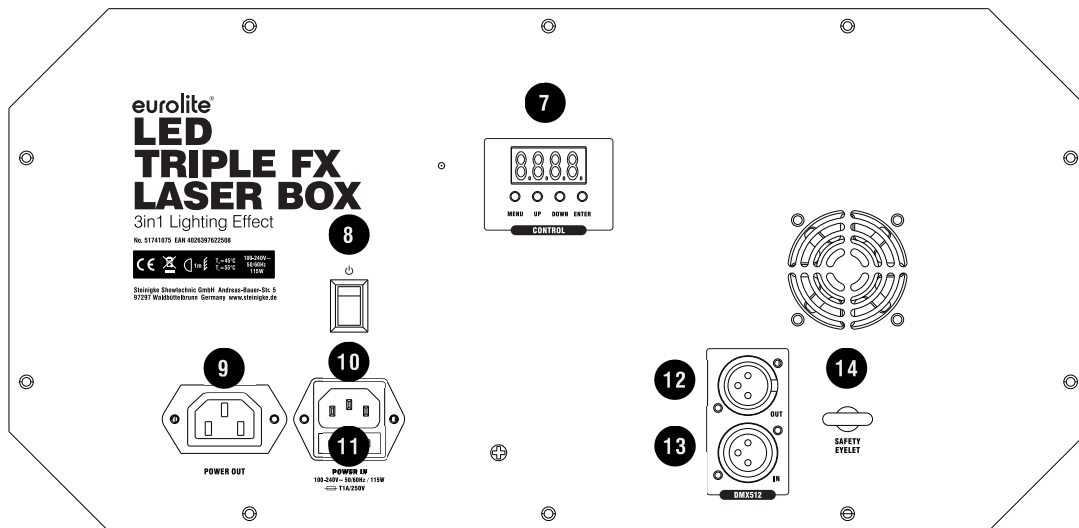
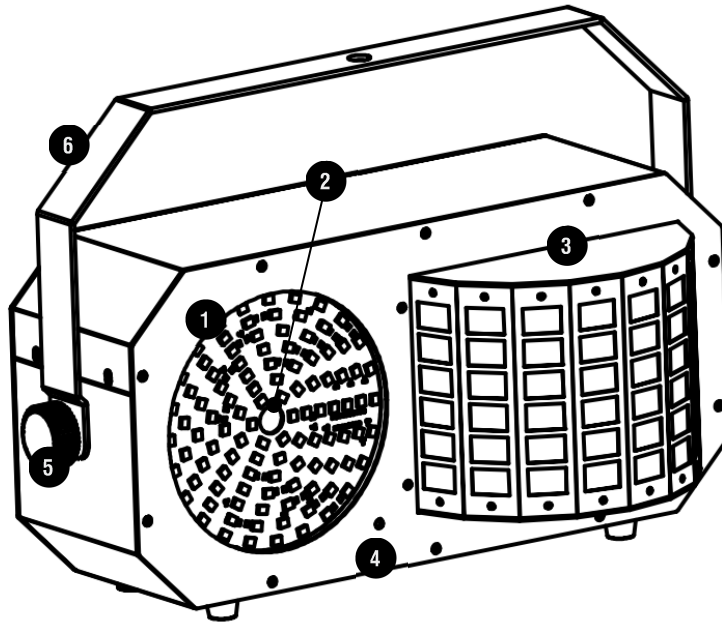

- | | |
|--|-------------------------------|
| (1) RGB LEDs for strobe/wash effects | (8) Power on/off |
| (2) Laser output aperture | (9) Power feed-through output |
| (3) RGBW LEDs for derby effects | (10) Power input |
| (4) Infrared receiver for the remote control | (11) Fuse holder |
| (5) Fixation screw | (12) DMX output |
| (6) Mounting bracket | (13) DMX input |
| (7) Display and operating buttons | (14) Safety eyelet |

INSTALLATION



WARNING! Risk of injury caused by falling objects

Devices in overhead installations may cause severe injuries when crashing down. Make sure that the device is installed securely and cannot fall down. The installation must be carried out by a specialist who is familiar with the hazards and the relevant regulations.



DANGER! Damage caused by laser radiation

Observe the chapter safety instructions when installing the device.

The device may be placed on the floor or fastened to a truss or similar rigging structure. The device must never be fixed swinging freely in the room.

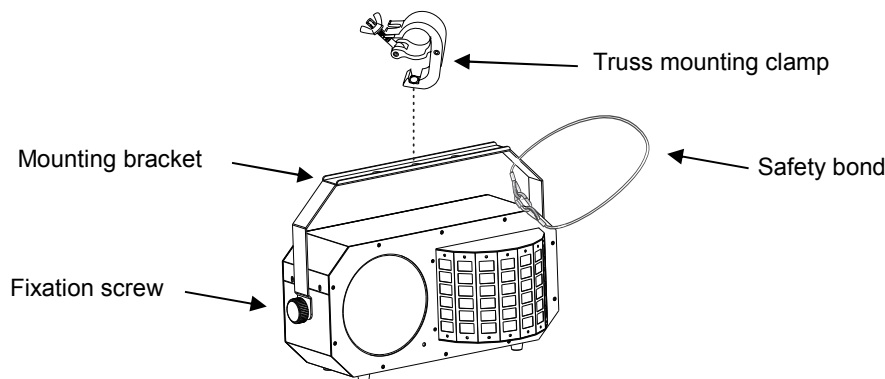

- 1 The rigging structure must support at least 10 times the weight of all fixtures to be installed on it.
- 2 Block access below the work area and work from a stable platform when installing the device.
- 3 Use rigging hardware that is compatible with the structure and capable of bearing the weight of the device. Please refer to the "Accessories" section for a list of suitable rigging hardware.
- 4 Secure the device with a safety bond or other secondary attachment. This secondary safety attachment must be sufficiently dimensioned in accordance with the latest industrial safety regulations and constructed in a way that no part of the installation can fall down if the main attachment fails. Pull the safety bond through the safety eyelet and fasten it in such a way that, in the event of a fall, the maximum drop distance of the device will not exceed 20 cm.
- 5 To align the device, release the fixation screws at the mounting bracket, adjust the desired inclination angle and retighten the fixation screws.
- 6 Make sure not to point the laser beams at highly reflective surfaces such as mirror balls, windows and shiny objects. As a precaution, remove or cover up highly reflective objects in order to avoid laser reflections.
- 7 After installation, the device requires inspections periodically to prevent the possibility of rot, deformation and looseness.

CONNECTIONS

DMX512 control

A DMX512 data link is required in order to control the device via DMX. The device provides 3-pin XLR connectors for DMX connection.

- 1 Connect the output of your DMX controller to the DMX input DMX IN of the light set with a DMX cable.
- 2 Connect the DMX output DMX OUT of the light set to the DMX input of the next unit in the chain. Always connect one output to the input of the next unit until all units are connected.
- 3 At the last unit, the DMX cable has to be terminated. Plug the terminator with a 120 Ω resistor between Signal (-) and Signal (+) in the DMX output of the last unit.
- 4 If the cable length exceeds 300 m or the number of DMX devices is greater than 32, it is recommended to insert a DMX level amplifier to ensure proper data transmission.

XLR connection:

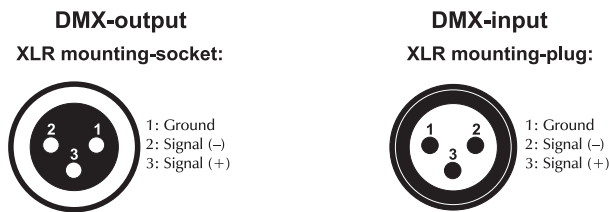

Connection to the mains

The device uses an auto-range power supply that accepts input voltages between 100 und 240 volts.

- 1 Connect the device via the mains cable to a grounded mains socket. Thus the unit is switched on.
- 2 To switch off the unit, disconnect the power plug.
- 3 Do not connect the unit to the mains voltage via a dimmer. For a more convenient operation, use a mains outlet which is switchable.

Power supply of further devices

The jack POWER OUT allows for power supply of further devices. To interconnect several devices, connect the jack POWER OUT to the input POWER IN of the next unit until all units are connected. Matching power cables with IEC plugs and IEC inline jacks are available as accessories. A maximum of 8 units can be linked.

OPERATION

Switch on the device. The display indicates the last operating mode. The operating modes can be selected by means of the display and the control buttons. All settings remain stored even if the device is disconnected from the mains. The device can be operated in stand-alone mode via the control board and the EUROLITE IR-26 remote control or in DMX-controlled mode via any commercial DMX controller.

Menu structure

Mode	Display		Function
DMX operation	Addr	001-512	Start address
DMX channels	ChMd	14CH	14 channels
		2CH	2 channels
Automatic mode	ShNd	Sh1	Show program 1: Derby
		Sh2	Show program 2: Strobe
		Sh3	Show program 3: Laser
		Sh4	Show program 4: Derby + Laser
		Sh5	Show program 5: Derby + Strobe
		Sh6	Show program 6: Laser + Strobe
		Sh7	Show program 7: Derby + Strobe + Laser
	SPEE	0-100	Program running speed slow > fast
Master/slave	SLMD	MASt	Master mode
		SLAV	Slave mode
Sound control	SoUn	ON OFF	Sound control on/off
	SoSE	0-100	Microphone sensitivity low > high
Behavior on loss of DMX signal	NodM	Prom	Master mode
		BLAC	Blackout mode
		HoLd	Last correct DMX value is held
Display illumination	LED	ON OFF	Display illumination on/off
Information	Ver	V10	Firmware version
Test program		Test	Test of all effects

Stand-alone mode

Automatic mode

In automatic mode, 7 show programs are available that run at an adjustable speed.

- 1 Press the **MENU** button so many times until **ShNd** is indicated in the display. Confirm with the **ENTER** button. Use the buttons **UP** and **DOWN** to select the desired show program. Confirm with the **ENTER** button.
- 2 Press the **MENU** button so many times until **SPEE** is indicated in the display. Confirm with the **ENTER** button. Use the buttons **UP** and **DOWN** to adjust the running speed of the program from **1** (slow) to **SP 100** (fast). Confirm with the **ENTER** button.

Sound control

Via the integrated microphone the unit can perfectly reproduce the show programs to the rhythm of the music (sufficient bass provided).

- 1 Press the **MENU** button so many times until **SoUn** is indicated in the display. Confirm with the **ENTER** button. Use the buttons **UP** and **DOWN** to select the **on** setting. Confirm with the **ENTER** button.
- 2 Press the **MENU** button so many times until **SoSE** is indicated in the display. Confirm with the **ENTER** button. Use the buttons **UP** and **DOWN** to Adjust the microphone sensitivity to the volume of the music (**0** = low, **100** = high).

Interconnecting several devices (master/slave operation)

Several devices may be interconnected (max. 32). Then all slave units can be synchronized and controlled with the master unit without the need for a DMX controller. The devices must be set to the corresponding operating modes.

- 1 Connect the DMX output of the master unit to the DMX input of the first slave unit. Then connect the DMX output of the first slave unit to the DMX input of the second slave unit, etc. until all units have been connected in a chain. Make sure the master unit is the first in the chain. Do not connect a DMX controller to the DMX input of the master unit.
- 2 Set all devices to the same DMX address (page 24).
- 3 Configure the master unit by pressing the **MENU** button so many times until **SLMD** is indicated in the display. Confirm with the **ENTER** button and use the buttons **UP** and **DOWN** to select the **MASt** setting. Confirm with the **ENTER** button.
- 3 The configure all slave units by pressing the **MENU** button so many times until **SLMD** is indicated in the display. Confirm with the **ENTER** button and use the buttons **UP** and **DOWN** to select the **SLAu** setting. Confirm with the **ENTER** button.
- 4 Set the master unit to the desired show program. The interconnected devices will now operate in sync.

Remote control IR-26

When actuating a button, always direct the remote control towards the sensor. There must be no obstacles between remote control and the sensor. In DMX and slave mode, the IR remote control is deactivated.

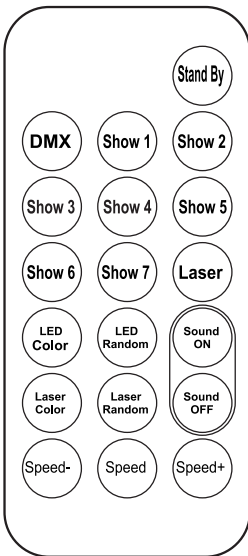

Button	Function
Stand By	LEDs off
DMX	DMX operation
Show 1-7	Show program 1-7 Running speed selection with Speed > Speed +/Speed -
LED Color	Color selection for the LEDs
LED Random	Random color selection for the LEDs
Laser	Laser beams on/off
Laser Color	Color selection for the laser beams
LED Random	Random color selection for the laser beams
Sound ON	Sound control on
Sound OFF	Sound control off
Speed +	Program running speed up
Speed -	Program running speed down
Speed	Medium program running speed

Notes:

- The remote control is supplied with a battery inserted. An insulating foil between the battery and the battery contacts prevents the battery from being discharged during storage. Prior to the first operation remove the foil from the battery support on the rear side of the remote control. Otherwise operation of the remote control is not possible.
- If the range of the remote control decreases, replace the battery. For this purpose, on the rear side of the remote control press the small bar with the groove to the right and at the same time remove the battery support. For operation, one 3 V button cell type CR 2025 is required. When inserting, pay attention that the positive pole of the button cell shows upwards in the support.
- Remove the battery from the remote control as a precaution if the device is not used for a longer period of time.

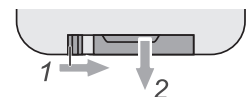

DMX operation

Setting the number of DMX channels and the DMX starting address

For operation with a controller with DMX512 protocol, the device is equipped with 14 control channels. However, it can also be switched to a mode with 2 channels if different functions are required. To be able to operate the device with a DMX controller, the DMX starting address must be set for the first DMX channel. The starting address depends upon which DMX controller is being used. Please refer to the controller's documentation.

- 1 Press the **MENU** button so many times until **Addr** is indicated in the display. Confirm with the **ENTER** button. Use the buttons **UP** and **DOWN** to set the address. Confirm with the **ENTER** button.
- 2 Press the **MENU** button so many times until the display indicates the DMX channel mode **ChMd**. Confirm with the **ENTER** button. Use the buttons **UP** and **DOWN** to select the desired number of DMX channels. Confirm with the **ENTER** button.

Note: Please make sure that you do not have any overlapping channels in order to control each device correctly and independently from any other fixture on the DMX chain. If several devices are addressed similarly, they will work synchronically.

DMX functions in 2-channel mode

Channel	Value	Function
1	000 – 009	No function
	010 – 044	Show program 1: Derby
	045 – 079	Show program 2: Strobe
	080 – 114	Show program 3: Laser
	115 – 149	Show program 4: Derby + Laser
	150 – 184	Show program 5: Derby + Strobe
	185 – 219	Show program 6: Laser + Strobe
	220 – 255	Show program 7: Derby + Strobe + Laser
2	000 – 247	Program running speed slow > fast
	248 – 255	Sound control

DMX functions in 14-channel mode

Channel	Value	Function
Master control		
1	000 – 009	No function
	010 – 044	Show program 1: Derby
	045 – 079	Show program 2: Strobe
	080 – 114	Show program 3: Laser
	115 – 149	Show program 4: Derby + Laser
	150 – 184	Show program 5: Derby + Strobe
	185 – 219	Show program 6: Laser + Strobe
	220 – 255	Show program 7: Derby + Strobe + Laser
RGBW color mix: if channel 1 is set to a value between 000-009		
2	000 – 009	Blackout
	010 – 198	Color selection (15) for the LEDs; each color takes up 15 DMX values
	199 – 225	4-color running light slow > fast
	226 – 255	15-color running light slow > fast
Show programs: if channel 1 is set to a value between 010-255		
2	000 – 247	Automatic show programs 1-7 Running speed slow > fast
	248 – 255	Sound-controlled show programs 1-7

Strobe LEDs		
3	000 – 009	No function
	010 – 244	Strobe effects slow > fast
	245 – 255	Strobe effects sound controlled
4	000 – 127	Rotation angle
	128 – 255	Rotation speed slow > fast
5	000 – 009	Strobe effect off
	010 – 255	Strobe effect with running light
6	000 – 127	Strobe effect off, running light slow > fast
	128 – 255	Strobe effect on, running light slow > fast
Laser beams		
7	000 – 009	No function
	010 – 127	Color selection laser beams
	128 – 255	Alternating laser beams
8	000 – 255	Pattern selection
9	000 – 063	Pattern size selection (index)
	064 – 127	Pattern size form small to large slow > fast
	128 – 191	Pattern size form large to small slow > fast
	192 – 255	Pattern size form large to small to large slow > fast
10	000 – 127	Rotation angle laser (index)
	128 – 191	Rotation clockwise
	192 – 255	Rotation counterclockwise
11	000 – 127	Horizontal position laser pattern (index)
	128 – 255	Horizontal motion laser pattern slow > fast
12	000 – 127	Vertical position laser pattern (index)
	128 – 255	Vertical motion laser pattern slow > fast
13 Motion macros	000 – 019	No function
	020 – 059	Horizontal motion right > left
	060 – 099	Vertical motion up > down
	100 – 139	Diagonal motion
	140 – 179	2-fold diagonal motion
	180 – 219	Circular motion large
	220 – 255	Circular motion small
14	000 – 255	Running speed motion macros (CH 13) slow > fast

CLEANING AND MAINTENANCE

The outside of the device should be cleaned periodically to remove contaminants such as dust etc. The lenses, in particular, should be clean to ensure that light will be emitted at maximum brightness.

- 1 Disconnect the device from power and allow it to cool before cleaning.
- 2 Clean the surface with a soft lint-free and moistened cloth. Never use alcohol or solvents as these may damage the surface. Make sure that no liquids can enter the device.
- 3 The device must be dry before reapplying power.

There are no serviceable parts inside. Do not open the housing. Do not try to repair the device by yourself as this may result in damage. Maintenance and service operations are only to be carried out by authorized dealers. Should you need any spare parts, please use genuine parts. Should you have further questions, please contact your dealer.

Replacing the fuse

If the fine-wire fuse of the device fuses, only replace the fuse by a fuse of same type and rating.

- 1 Disconnect the device from power and allow it to cool.
- 2 Open the fuse holder of the mains connection with a fitting screwdriver.
- 3 Remove the old fuse from the fuse holder and replace it with a new fuse.
- 4 Carefully push the fuse holder back into its position before reapplying power.

TECHNICAL SPECIFICATIONS

Power supply:	100-240 V AC, 50/60 Hz
Power consumption:	115 W
Protection class:	I
Fuse:	T1A, 250V
Laser classification:	2M
Laser modules:	Red 100 mW, green 30 mW
Wavelength:	Red 650 nm, green 532 nm
LEDs:	
Derby effect:	2 x 10 W RGBW (4in1)
Strobe effect:	105 x 0.2 W RGB (3in1)
Flash rate:	0-20 Hz
DMX channels:	2/14
DMX connection:	3-pin XLR
Sound control:	via built-in microphone
Dimensions (L x W x H):	220 x 500 x 300 mm
Weight:	5.3 kg

Accessories

EUROLITE TPC-10 Coupler, silver	No. 59006856
EUROLITE TPC-10 Coupler, black	No. 59006858
EUROLITE Safety Bond A 4x1000mm up to 15kg silver	No. 58010320
EUROLITE Safety Bond A 4x1000mm up to 15kg black	No. 58010344
EUROLITE DMX cable XLR 3pin 3m bk	No. 3022785H
PSSO DMX cable XLR 3pin 3m bk Neutrik	No. 30227810
SOMMER CABLE DMX cable XLR 3pin 3m bk Hicon	No. 30307457
SOMMER CABLE DMX cable XLR 3pin 3m bk Neutrik	No. 3030746Z
OMNITRONIC IEC Extension 3x1.0 3m bk	No. 30235201
EUROLITE IR-26 Remote Control	No. 50530584

All information is subject to change without prior notice. © 06.09.2018

eurolite®

Eurolite is a brand of Steinigke Showtechnic GmbH Andreas-Bauer-Str. 5 97297 Waldbüttelbrunn Germany
D00112264 Version 1.1 Publ. 06/09/2018

